

**NESTOR
MARTIN**

INSTALLATION AND OPERATING INSTRUCTIONS



S33

H33

R33

X33

**EPA-CERTIFIED NONCATALYTIC WOODSTOVES
WITH WOODBOX® TECHNOLOGY**

Manufactured by:
Fonderies du Lion Development
11 Rue du Lion
5660 Couvin, Belgium

SAVE THESE INSTRUCTIONS FOR FUTURE REFERENCE

Dear Customer,

We would like to thank you for purchasing a Nestor Martin heating appliance. For over 150 years, we have provided our customers with high-quality, worry-free products that stand the test of time. We work hard so that you can enjoy the warmth of your new stove for years to come.

If you have questions that are not covered in this manual, please feel free to contact your local Nestor Martin dealer for more information.

Rudy Cyris
President

Table Of Contents

	Page
Safety Notice	3
Product Specifications	3
Installation Guide	4
Dimensions S33 and H33	4
Clearances to Combustibles S33 and H33	4
Dimensions X33 and R33	5
Clearances to Combustibles X33 and R33	5
Floor Protection Requirements	6
Types of Chimneys	6
Chimney Inspection	6
Draft Requirements	7
Chimney Height	7
Standard Installation Procedure	8
Freestanding Installations	8
Above a Fireplace	9
Wall Pass-Throughs	9
Acceptable Types of Connector Pipe	10
The Woodbox Combustion System	11
Air Distribution System	11
Controlling Components	11
The Air Intake Controls	12
Operating Instructions	13
Lighting a Fire	13
Use of the Remote Control	14
Refuelling the Stove	14
Overnight Burning	14
Ash Removal	15
Guidelines for Safe Operation	15
Flue Gas Temperature	15
Unattended Fires	16
In Case of a Chimney Fire	16
Choice of Firewood	17
Maintenance	17
Integrated Airwash System	17
Manual Cleaning of the Glass	17
Cleaning the Stove Body	17
Creosote Formation	18
Summer Shut Down	18
Door Handle Adjustment	19
Ash Pan Door Adjustment	19
Spare Parts	20
Spare Parts, S33	20
Spare Parts, H33	22
Spare Parts, X33	24
Spare Parts, R33	26
Safety Labels	28
Warranty	30

Safety Notice

Please read this entire manual before you install and use your new room heater. Failure to follow instructions may result in property damage, bodily injury or even death.

If your stove is not properly installed, a house fire may result. For your safety, follow the installation directions. Contact local building or fire officials about restrictions and installation requirements in your area.

The authority having jurisdiction (such as municipal building department, fire department, fire prevention bureau, etc.) should be consulted before installation to determine the need to obtain a permit.

ENSURE THAT THIS MANUAL REMAINS WITH THE APPLIANCE AND IS PASSED ON TO THE USER AFTER INSTALLATION. DO NOT STORE OR USE GASOLINE OR OTHER FLAMMABLE VAPORS AND LIQUIDS IN THE VICINITY OF THIS APPLIANCE.

WARNING: Improper installation, adjustment, alteration, service or maintenance can cause injury or property damage. Refer to this manual for assistance or consult a qualified (experienced) installer.

Product Specifications

Flue collar size:	6"
Flue position:	top
Max burn rate:	59,000 BTU/hr
EPA output range:	8,600 – 37,300 BTU/hr
Emissions rate:	3.43 g/hr
Heating capacity:	1,100 – 1,500 sq ft
Max. burn time:	up to 10 hours
Max log length:	17"
Weight:	H33: 346 lbs S33: 358 lbs R33: 316 lbs X33: 316 lbs

Safety Listing

Your appliance has been tested following standards :

US Standard: ANSI/UL 1482

Canadian Standard : CAN/ULC-S627

Tests performed by OMNI-Test Laboratories, Inc., Beaverton, Oregon

This stove meet the US Environmental Protection Agency's emissions limits for wood heaters.

Installation Guide

S33 and H33 cast iron models

Dimensions

	S33	H33
A	30" (751mm)	28" (716mm)
B	25" (631mm)	26" (649mm)
C	16" (395mm)	15" (370mm)
D	6" (150mm)	6" (150mm)
E	32" (816mm)	31" (781mm)
F	5" (113mm)	5" (113mm)

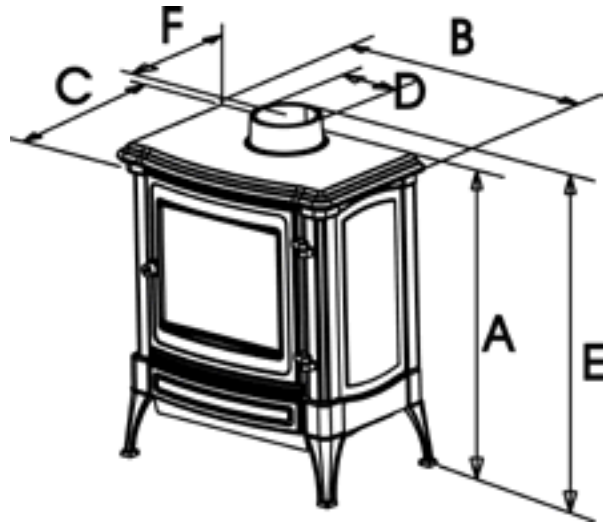

Clearances to Combustible Materials

The following clearances may only be reduced by means approved by the regulatory authority.

Back and side wall clearances

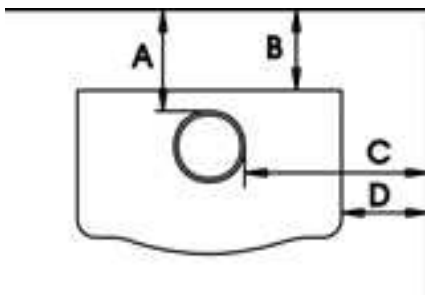

Connector pipe	A	B	C	D
Single wall	14"	13"	18"	9"
Double wall	13"	12"	18"	9"

Minimum ceiling height: 30" (unit to ceiling)

Corner clearances

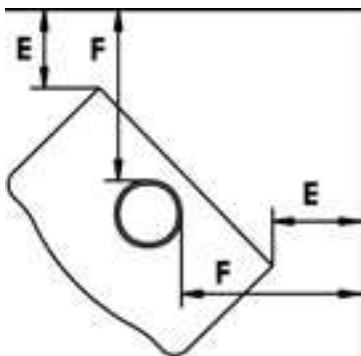

Connector pipe	E	F
Single wall	10½"	19"
Double wall	7"	15½"

Minimum ceiling height: 30" (unit to ceiling)

Alcove clearances

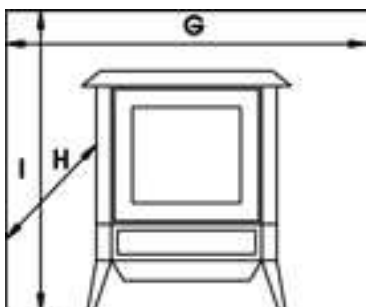

Connector pipe	G	H	I
Double wall	48"	28"	60"

X33 and R33 steel body models

Dimensions

	X33	R33
A	31 ³ / ₄ " (807 mm)	31 ³ / ₄ " (807 mm)
B	16 ¹ / ₄ " (390 mm)	16 ¹ / ₄ " (390 mm)
C	16" (404 mm)	15 ³ / ₄ " (400 mm)
D	6" (150 mm)	6" (150mm)
E	37" (942 mm)	37" (942 mm)
F	5 ¹ / ₄ " (132 mm)	5" (113mm)
G	21" (542 mm)	21" (542 mm)

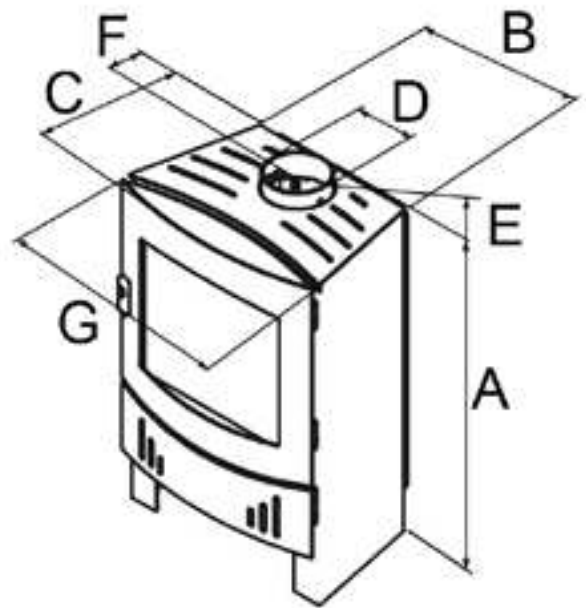

Clearances to Combustible Materials

The following clearances may only be reduced by means approved by the regulatory authority.

Back and side wall clearances

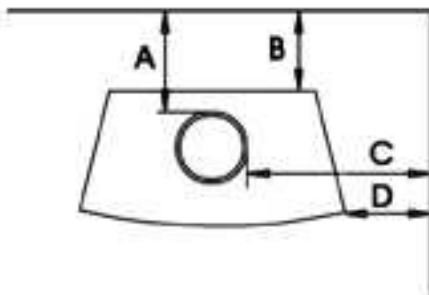

Connector pipe	A	B	C	D
Single wall	11"	10"	24"	18 ¹ / ₂ "
Double wall	8"	7"	23"	17 ¹ / ₂ "

Minimum ceiling height: 30" (unit to ceiling)

Corner clearances

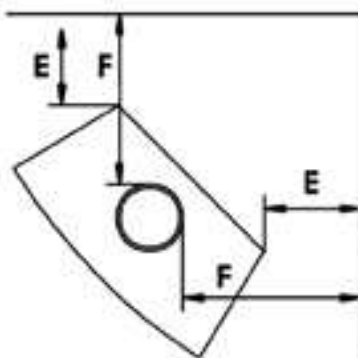

Connector pipe	E	F
Single wall	10"	15 ¹ / ₂ "
Double wall	9 ¹ / ₂ "	15"

Minimum ceiling height: 30" (unit to ceiling)

Alcove clearances

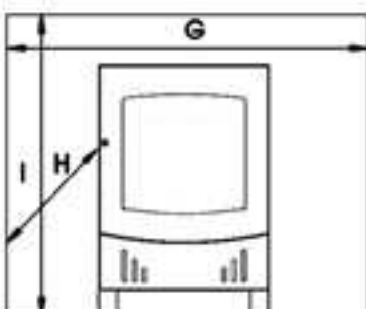

Connector pipe	G	H	I
Double wall	48"	28"	60"

Floor Protection Requirements

A non-combustible floor protector (hearth extension) must be installed under the unit. Check with local building authorities as to what other materials are acceptable.

The floor protector must extend:

1. Beyond the front door, a minimum of 16 inches (400 mm) in USA and 18 inches (450 mm) in Canada. See measurement "B" on the floor protection drawing below.
2. On both sides of the unit, a minimum of 5 inches (125 mm) in USA and 8 inches (200 mm) in Canada. See measurement "C" below.
3. On the back of the unit, a minimum of 0" (0 mm) in USA and 8 inches (200 mm) in Canada. See measurement "A" below.

Notice: In case of installation with horizontal pipe, the floor protection must be extended beyond the back of the appliance under the chimney connector and 2" (50 mm) beyond each side of the chimney connector.

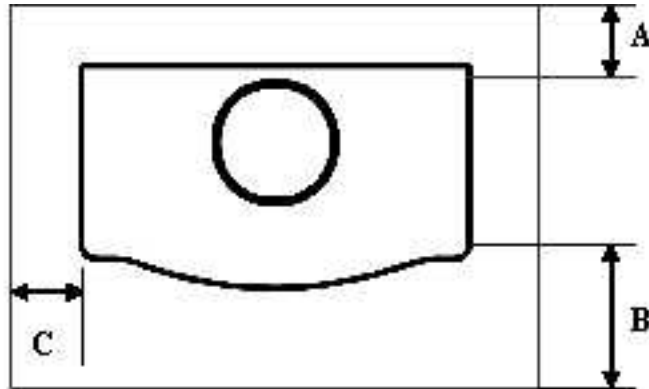

Minimum requirements for floor protection on combustible floors

Types of Chimneys

The Chimney is a vital part of your stove installation. Your stove must be connected to either a code-approved masonry chimney (a flue liner may be required), or a 6-inch diameter factory built chimney complying with the UL requirements for Type HT chimneys (regulation UL 103 and ULC S629).

All chimneys must be installed either according to the local building codes in the case of a masonry chimney or according to the chimney manufacturer's instructions in the case of a factory-built metal chimney. See the chimney manufacturers instructions for exact specifications. An oversized chimney may result in less than optimum performance. Installations into a large, masonry chimney may require a liner to improve performance.

Chimney Inspection

Existing chimneys must be inspected before installing your stove. Consult your local building department for chimney code requirements. A masonry chimney should have a code-approved liner. This liner must not have broken or missing pieces. Some non-code masonry chimneys may be brought up to code by being relined. (Consult your dealer or qualified chimney sweep.) Factory built metal chimneys should also be inspected, first for creosote deposits (which would be removed), and then for integrity of the stainless steel liner. Look for obvious bulges in the lining, which may indicate the need to replace that section (use a bright flashlight). Also inspect the attic to see that the chimney has proper clearance to combustible framing members.

Draft Requirements

The appliance is merely one component of larger system. The other equally important component is the venting system. This is necessary for achieving the required flow of combustion air to the fire chamber and for safely removing unwanted combustion by-products from the appliance. If the venting system's design does not promote these ends, the system may not function properly. Poorly functioning venting systems may create performance problems, as well as be a safety hazard (i.e. an oversized chimney may result in less than optimum performance. Installations into a large masonry chimney may require a liner to improve performance).

THE RECOMMENDED DRAFT REQUIREMENTS FOR YOUR STOVE IS NO LESS THAN $-.04$ AND NO GREATER THAN $-.08$. OPERATION OF YOUR STOVE WITH A DRAFT GREATER THAN $-.08$ CAN POSSIBLY CAUSE DAMAGE TO THE STOVE AND VOID THE WARRANTY.

SPECIAL NOTE: A barometric damper is recommended for installations of stoves in areas that may have high winds, which can affect the draft. The installation must be only in units with a newly constructed chimney, free of creosote deposits. The barometric damper is an automatic device designed to regulate the draft in a heating appliance, which in turn, stabilizes the chimney temperatures, lessening the potential of over-firing. Do not place the barometric damper greater than 24 inches (610 mm) above the unit. Excessive draft will lead to poor control of the burn rate, possible over-firing of the stove and damage to the cast iron components of the firebox. Most barometric dampers are calibrated in inches of water column and can be set to draft requirements of $-.03$ to $-.08$ inches (-7.5 to -20 Pa). It is recommended that the barometric dampers to be set between $-.05$ and $-.06$ inches.

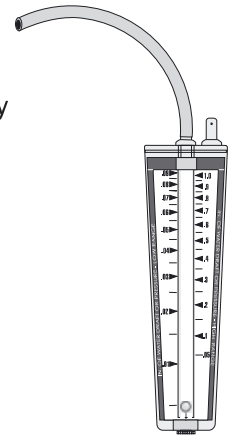

Draft gauge

Chimney Height requirements

According to the American National Standards Institute ANSI/NFPA 211-92, draft 1-7, a chimney or vent shall be so designed and constructed to develop a flow sufficient to completely remove all flue and vent gases to the outside atmosphere. The venting system shall satisfy the draft requirements of the connected appliance in accordance with the manufactures instructions.

The "3-foot, 2-foot, 10-foot rule" on chimney height states that a chimney must be:

1. At least 3 feet higher than the highest part of the roof opening through which it passes,
2. and at least 2 feet higher than any part of the roof within 10 feet, measured horizontally.

Due to prevailing winds, local terrain, adjacent tall trees, a hill or ravine near the home, or adjacent structures, additional chimney height or a special chimney cap may be required to assure optimum performance.

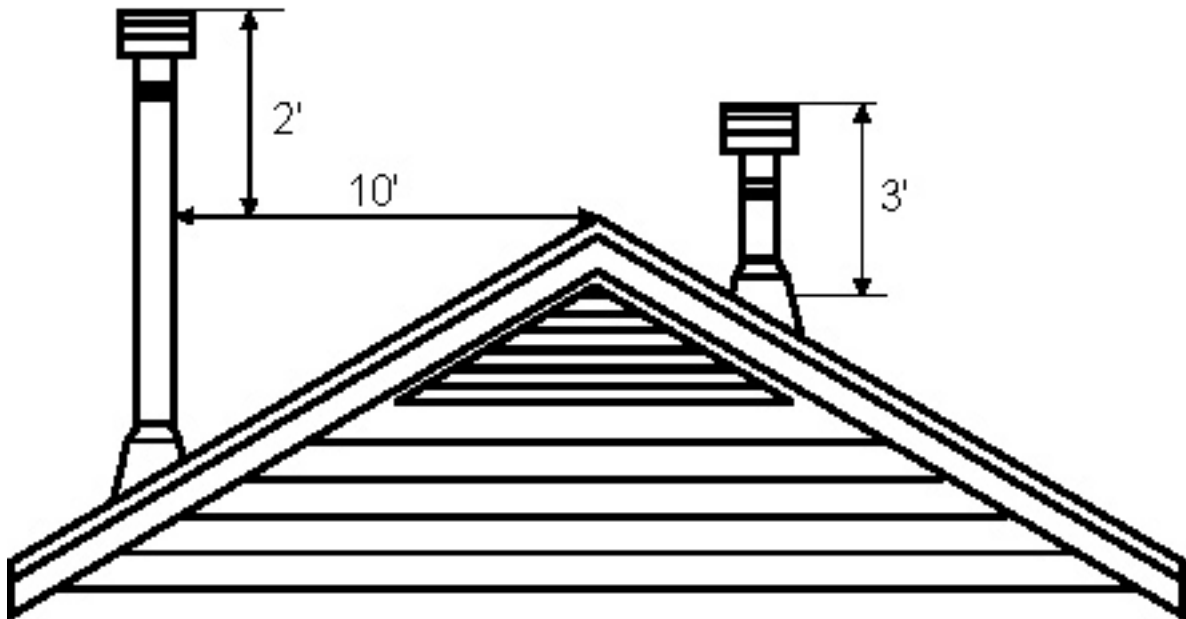

Standard Installation Procedure

1. Position the unit no closer than the minimum clearances to combustible materials. Check that no overhead cross members in the ceiling or roof will be cut. Reposition unit if necessary, being careful not to move closer than the minimum clearances.
2. Mark the position of the required floor protector on the floor. Remove the unit and install the floor protector.
3. Position the unit on the floor protector at the proper clearances.
4. Install a 6-inch diameter, minimum 24 MSG black or 26 MSG blued steel connector pipe on the flue collar of the unit.
5. The stove is NOT to be connected to any air distribution duct or system. A chimney connector shall not pass through an attic or roof space, closet or similar concealed space, or a floor, or ceiling. Where passage through a wall or partition of combustible construction is desired, the installation shall conform to CAN/CSA-B365, Installation Code for Solid-Fuel-Burning Appliances and Equipment. (Canadian installations only).
6. Use a 6" chimney connector adapter to connect the chimney connector up to the chimney. The small ends of the chimney connector should all point down to ensure a drip-free installation.
7. Check that all clearances are still within the allowable tolerances.
8. Secure adjoining sections of chimney connector to each other using three equally spaced sheet metal screws. Secure the connector pipe to flue collar using three equally spaced sheet metal screws. DO NOT secure chimney connector to chimney with screws.
9. The unit must be connected to either:
 - a code-approved masonry chimney with a flue liner, or
 - a 6 inch diameter factory built chimney complying with the requirements for Type HT chimneys in the standard UL 103 and ULC S629.

WARNING:

DO NOT CONNECT THIS UNIT TO A CHIMNEY FLUE SERVING ANOTHER APPLIANCE.

UNIT MUST BE INSTALLED ACCORDING TO ALL LOCAL CODES. A BUILDING PERMIT MUST BE OBTAINED BEFORE INSTALLING.

SAVE THESE INSTRUCTIONS FOR FUTURE REFERENCE.

DO NOT INSTALL IN A MOBILE HOME.

READ ALL INSTRUCTIONS CAREFULLY BEFORE STARTING THE INSTALLATION.

UNIT MUST BE PROPERLY INSTALLED OR LISTING WILL BE VOID.

INSTALLATIONS OTHER THAN THOSE SPECIFICALLY COVERED HEREIN HAVE NOT BEEN CONFIRMED BY TEST AND ARE NOT COVERED BY THE LISTING.

Freestanding Installations

If the chimney connector must pass through a combustible wall to reach the chimney, follow the recommendations in the Wall Pass-Through section that follows.

The opening through the chimney wall to the flue (the "breach") must be lined with either a ceramic or metal cylinder, called a "thimble", which is securely cemented in place.

Most chimney breeches incorporate thimbles, but the fit must be snug and the joint between the thimble and the wall must be cemented firmly (Fig. A)

A special piece called the "thimble sleeve", slightly smaller in diameter than standard connectors and most thimbles, will facilitate the removal of the chimney connector system for inspection and cleaning. Thimble sleeves are available from your local dealer.

To install a thimble sleeve, slide it into the breach until it is flush with the inner flue wall. Do not extend it into the actual flue passage, as it could interfere with the draft.

The thimble sleeve should protrude 1-2" (25-50 mm) into the room. User fire cement and thin gasketing to seal the sleeve in place in the thimble. Secure the chimney connector to the outer end of the sleeve with sheet metal screws.

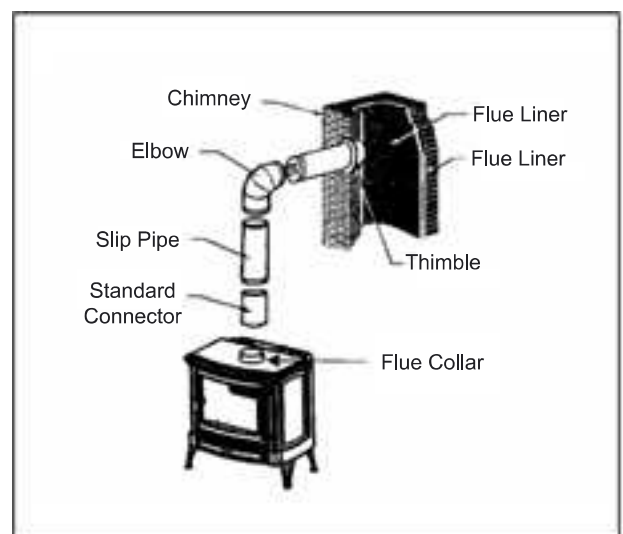

Fig. A: Chimney connection in a freestanding installation

Above a Fireplace

In this type of installation, the chimney connector rises from the stove, turns 90°, and then goes into the fireplace chimney (Fig. B) The liner of the fireplace chimney should extend at least to the point at which the chimney connector enters the chimney. Follow all the guidelines for installing a chimney connector into a freestanding masonry chimney, and pay special attention to these additional points:

- Double check the connector clearance from the ceiling: 18" minimum.
- The fireplace damper must be closed and sealed to prevent room air from being drawn up the flue, thereby reducing the draft. However, it must be possible to re-open the damper in order to inspect the chimney.

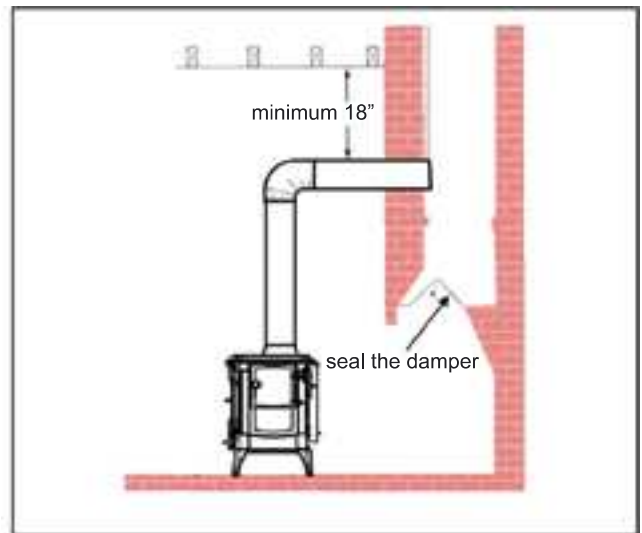

Fig. B: Chimney connector enters the chimney above a fireplace

Wall Pass-Through

Whenever possible, design your installation so that the wall connector does not pass through a combustible wall. If you are considering a wall pass-through in your installation, check with your building inspector before you begin. Also check with the chimney connector manufacturer for any specific requirements. Accessories are available for use as wall pass-throughs. If using one of these, make sure it has been tested and listed for use as a wall pass-through.

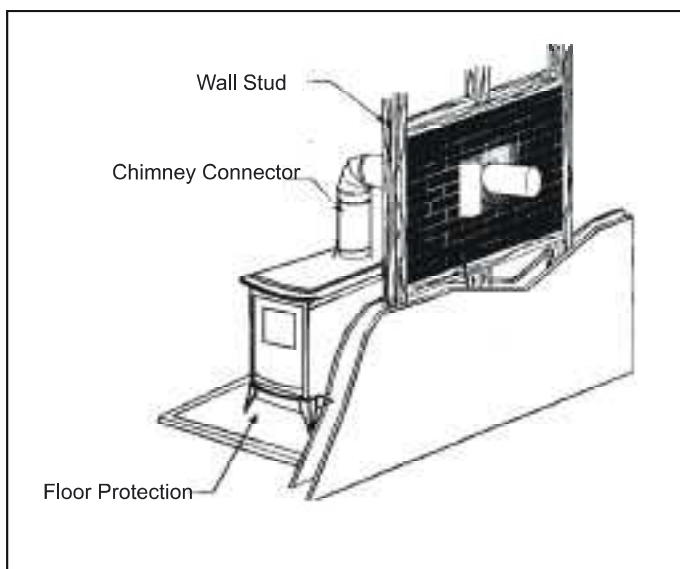

Fig. C: An example of an approved wall pass-through

The National Fire Protection Association (NFPA) has established guidelines for passing chimney connectors through combustible walls. Many building code inspectors follow these guidelines when approving installations.

The methods approved by the NFPA are:

- Cutting away all combustible material in the wall a sufficient distance from the single wall connector, to provide the required 12" (300 mm) clearance for the connector. Any material used to close the opening must be non-combustible (as in Fig . C).
- Using a section of double-wall chimney with a 9" (230 mm) clearance to combustibles.
- Placing a chimney connector pipe inside a ventilated thimble, which is then separated from combustibles by 6" (150 mm) of fiberglass insulating material.
- Placing a chimney connector pipe inside a section of 9" (230 mm) diameter, solid-insulated factory built chimney, with two inches of air space between the chimney section and the combustibles.

Acceptable Types of Connector Pipe

Minimum Flue Diameter: Minimum 6", Maximum 10"

Minimum recommended chimney height (from appliance to termination): 12'-15'

- When Using Single Wall Pipe: Install a 6-inch diameter, single wall, 24 MSG black steel or 26 MSG blued steel connector pipe on the flue collar of the unit. The crimped ends of the pipe should all point down. Additional sections of single wall pipe should be fastened together with at least three sheet metal screws each section. All pipe connections must be sealed (using high temperature silicone).
- When connecting to the factory-built ceiling support package, use the manufacturer's transition piece, usually called a dripless connector, to join single wall pipe to their factory-built chimney section.
- When using approved double wall pipe: Type L and listed doublewall connector pipe is acceptable. Install any factory-built brand of pipe according to the manufacturer's instructions. All pipe connections must be sealed.
- Chimney Connector Adapter - Use a 6-inch chimney connector adapter to connect the chimney connector up to the chimney. The small ends of the chimney connector should all point down for a drip free installation. Secure adjoining sections of chimney connector to each other using three sheet metal screws. Secure the connector pipe to flue collar using three sheet metal screws. DO NOT secure chimney connector to chimney with screws.
- Connection to a factory built chimney - Your stove may be connected to a factory-built chimney conforming to CAN / ULC – S629, Standard for 650°C Factory-Built Chimneys. All pipe connections must be sealed.
- For Reduced Residential Clearances Using Double Wall Pipe: Type L and listed double wall connector pipe is acceptable. Install any factory-built brand of pipe according to the manufacturer's instructions.

The Woodbox[®] Combustion System

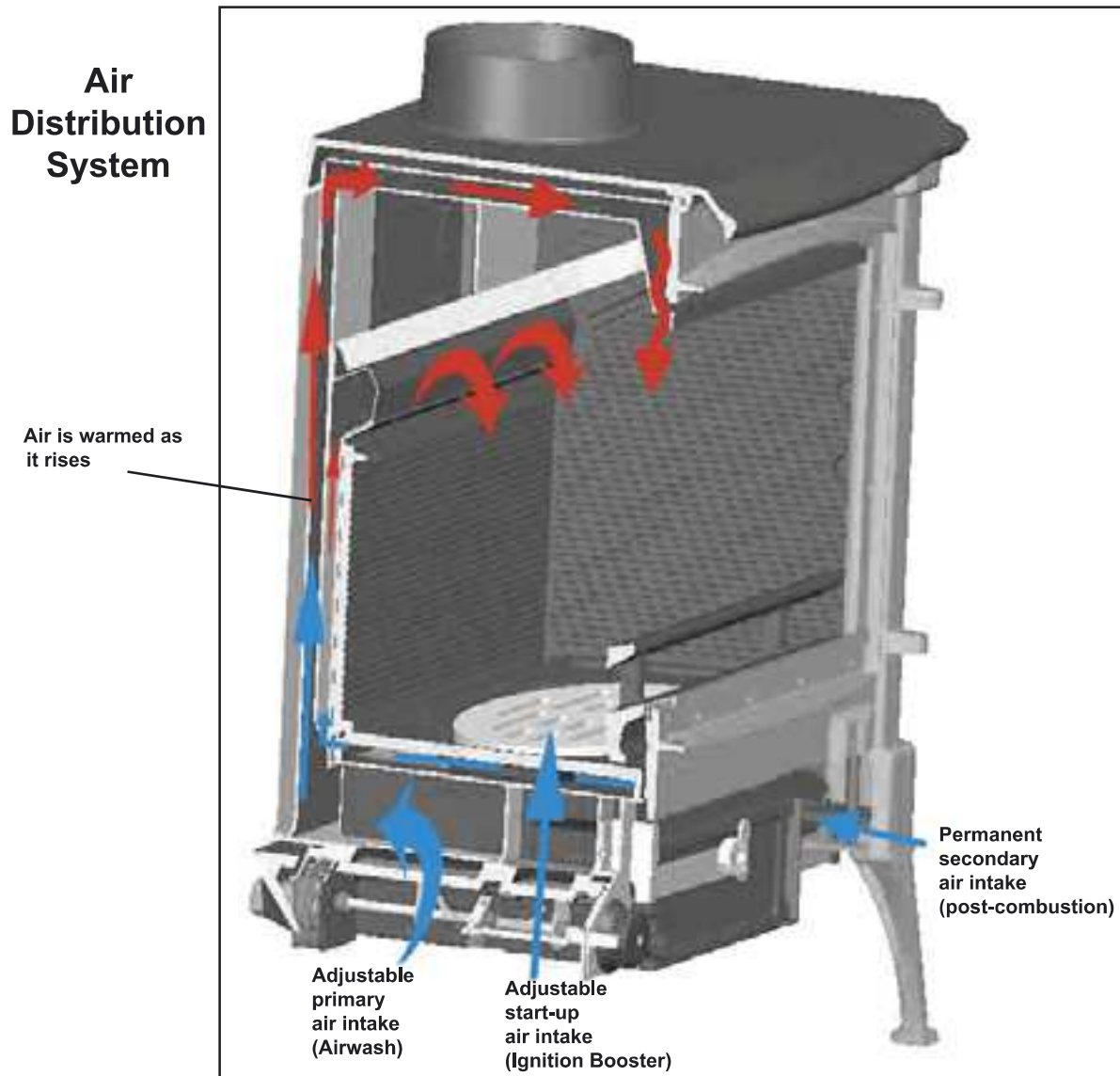

Note: For the purpose of clarity, the refractory bricks lining the firebox are not shown in the illustration above.

Controlling components

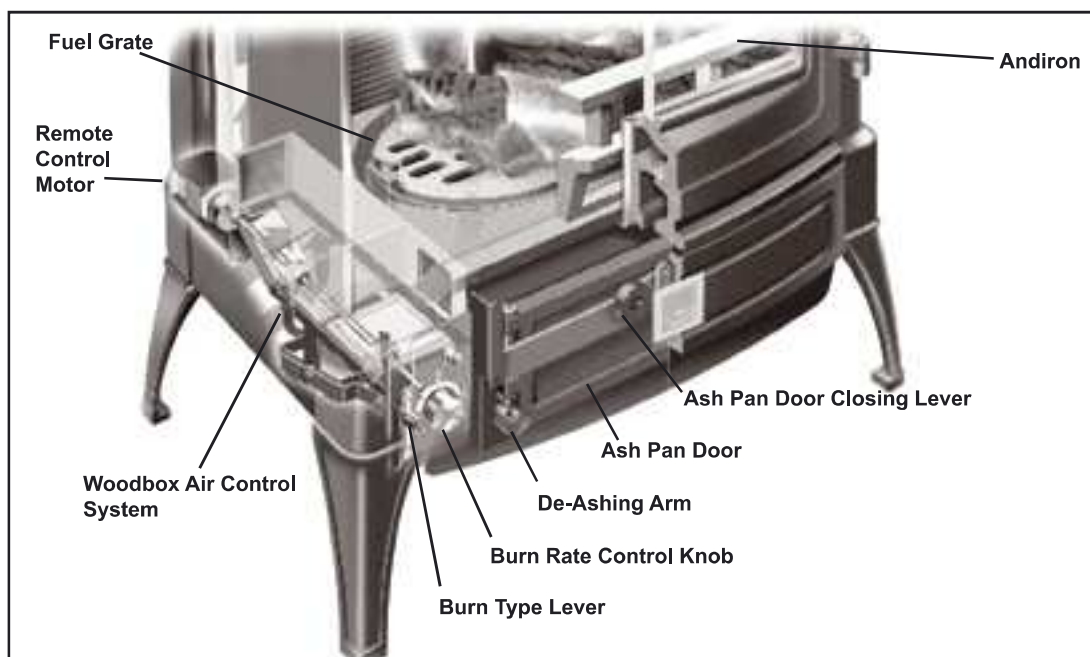

Explanation of the Air Intake Controls

The Burn Rate Control Knob

The burn rate is controlled simply by rotating the control knob with the tool provided.

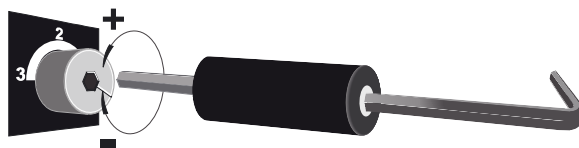

As the knob is rotated counterclockwise, the cam progressively opens the air shutter to allow an increasing amount of air into the stove.

Because the air entering the stove is not only dependent upon the position of the flap but also the performance and temperature of the chimney, the setting of the control knob for a particular fire size will vary.

Generally speaking, any setting beyond "2" will normally only be used when lighting the fire.

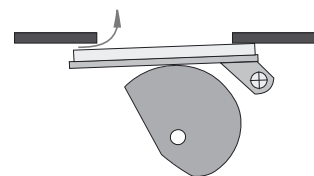
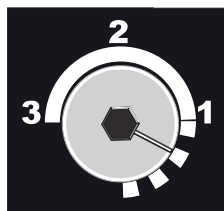

Low Operation

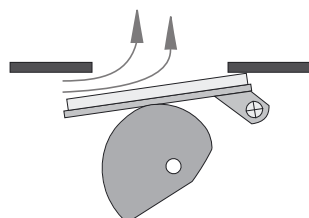
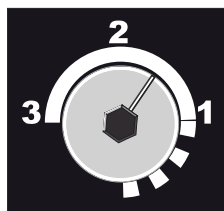

Normal Operation

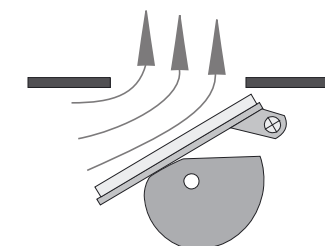
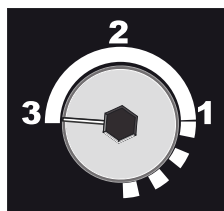

Lighting

The Burn Type Selection Lever

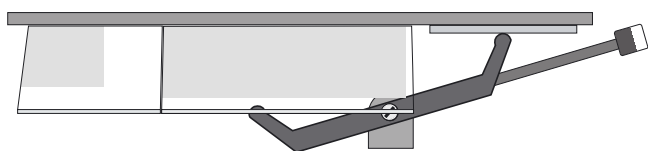

Post-combustion and airwash shutters open, providing top air for optimal wood burning. Under-grate air flap closed.



Position A for normal operation

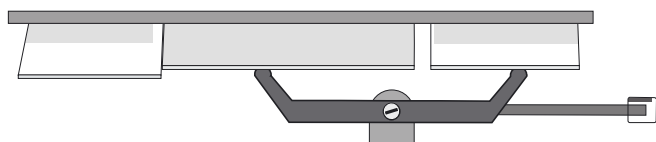

All air shutters open, providing maximum air intake above and below grate for ignition.



Position B for lighting

Operating Instructions

WARNING : DO NOT USE GASOLINE, LIGHTER FLUID, KEROSENE OR OTHER FLAMMABLE LIQUIDS TO START OR FRESHEN A FIRE IN THIS HEATER. KEEP ALL SUCH LIQUIDS WELL AWAY FROM THE HEATER WHILE IT IS IN USE.

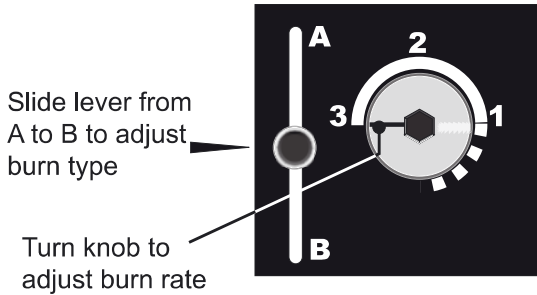

Use the tool provided to adjust the stove's air controls



WARNING: Touching the air controls with bare hands while the stove is in operation may result in severe burns

Lighting a Fire

1. Open the ashpan door to access the air controls. Open the start up air intake by sliding the Burn Type Lever to position B. Be sure the ash drawer is closed and secured.
2. Open the Burn Rate Knob all the way by turning to the left. (on position 3). This knob may be turned manually (using the tool provided) or by pressing on the corresponding button on the remote control (see remote control manual).

Burn Rate Knob set to maximum (3) when lighting

Burn Type Lever set to its lower most position (B) when lighting

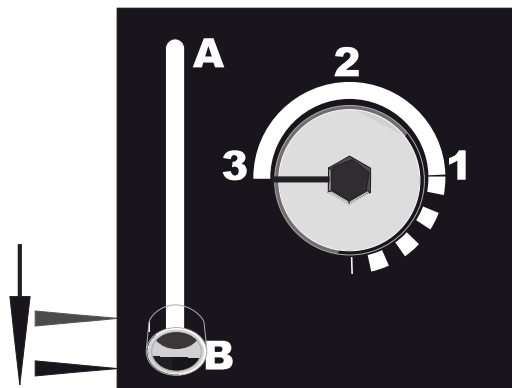

The burn rate knob is rotated fully counter-clockwise to supply the stove with the maximum quantity of air because the flue will be cold. The burn type lever is set to its lower position to supply air to the fire from beneath the grate, accelerating the speed at which the fire size increases, as well as air above the fire to burn the volatile matter, reducing the smoke and lessening the production of glass staining tars.

3. Place 5 or 6 loosely crumpled sheets of newspaper in the bottom of the stove. Add a small amount of dry kindling on the top of the newspaper. Place a few more loosely crumpled newspapers on top of the kindling and light the bottom paper first, then light the top paper. The upper fire should preheat the chimney and create an effective draft while the lower fire ignites the kindling. Close the stove door.

WARNING : DO NOT USE SUPPLEMENTAL GRATES, ANDIRONS, OR OTHER FUEL SUPPORT METHODS OTHER THAN THOSE SUPPLIED WITH THE STOVE.



TIPS ON BURNING WOOD

- Burn only dry seasoned wood.
- Control the fire with the **Burn Rate Control Knob** only.
- Do not operate with under-grate air
- Open the front door with caution when the appliance is in use.
- Load wood in such away that combustion air can pass between the logs. Do not stack the wood tightly together.

4. After the kindling is burning well, add increasingly larger pieces of wood until the fire is actively burning.
5. When the fire is well established, slide the Burn Type Lever to position A. Then adjust the Burn Rate Knob to the desired heat output, either manually or with the remote control.

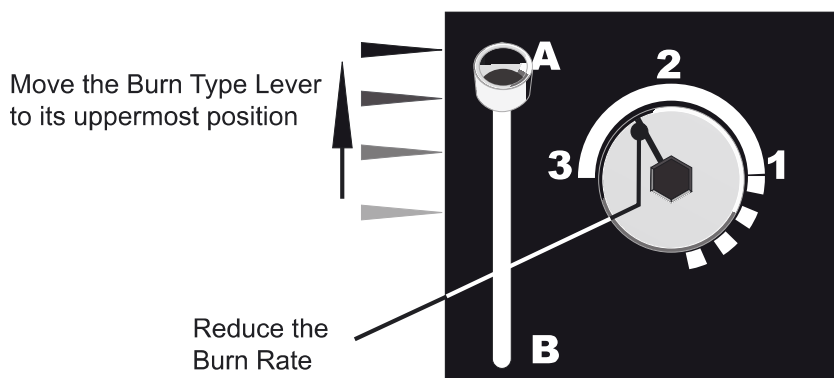

As the fire grows and the flue warms, the Burn Type Lever can be moved in one or two stages to its uppermost position (A), and the Burn Rate Knob moved progressively (clockwise) to lower settings. Much will depend on the quality of the wood being used and the performance of the flue but the stove will normally be operating with the Burn Type Lever at position "A" and the Burn Rate Control reduced within a few minutes of lighting.

Do not position the Burn Type Lever in the low position ("B") during operation except during lighting. The stove is designed to burn in a way that ensures all the volatile gases produced by the wood burn in a regulated manner. Introducing too much under-grate air will induce the wood to release more volatiles than the air supply can cleanly burn. If too much under-grate air is used when lighting, the volatiles released will chill below their ignition temperature, resulting in stained glass.

Use of the Optional Remote Control

This stove has the option of remote control. For full operating instructions for the remote control refer to the Remote Control Guide (ref. 22492).

Refuelling the Stove

Before reloading, rake a portion of the embers as well as any partially-burned logs towards the front of the stove. Place the new logs towards the back of the stove, as this will minimize the possibility of smoke reaching the glass and of the wood itself falling against the glass.



After reloading, close the stove door and turn the Burn Rate Knob to high setting for a while to re-establish a lively fire. Once the wood is burning at a brisk rate, turn the knob down to the desired heat output.

Refuelling "little and often" will give the most visually satisfying stove, and until you gain the experience in operating your stove it will be the simplest method of operation. Successfully burning large charges of fuel is only possible when you understand the operation of your stove, the performance of your chimney, and the characteristics of the wood you are burning.

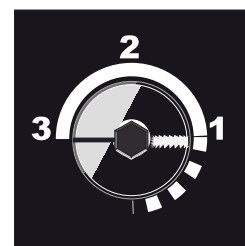

Overnight Burning

If you fill your appliance with wood and close all air supplies (Burn Type Lever to A and Burn Rate Knob to 0), it is possible to achieve overnight burning though it is probable that the window glass will become dirty. To keep the glass clean, we recommend you do not shut the air control knob completely but to leave it slightly open (on position 1), depending on how the chimney draws, to achieve slow burning for a maximum of 8 to 10 hours (with dry, good quality wood such as oak...). With a well-drawing chimney, the air control will need to be closed further than with poor drawing chimneys. Do not load un-split, round section logs as these will likely roll onto the glass and cause staining.

Ash Removal

Empty the ash pan regularly to prevent the ash from spilling over. Do not allow ash to build up and touch the under side of the grate.
A layer of ash left over the grate when burning wood will protect the grate, retain heat, and promote clean combustion.

CAUTION: THE ASH PAN MAY BE HOT. USE HIGH TEMPERATURE GLOVES.

Use the tool provided to open the latch on the ashpan door. It is best to empty the ashpan while the stove is not in operation.

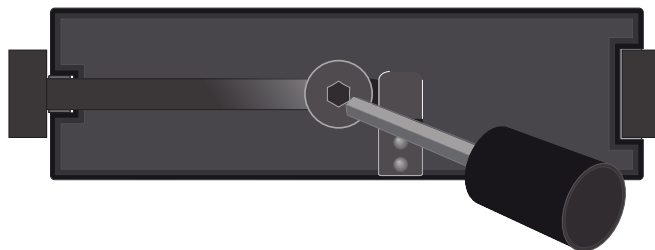

To remove the ashes from the stove, push them down through the centre grate using the tool provided. Place ashes in a metal container with a tight fitting lid. The closed container of ashes should be placed on a non-combustible floor or on the ground, well away from

all combustible materials, pending final disposal. If the ashes are disposed of by burial in soil or otherwise locally dispersed, they should be retained in the closed container until all cinders have thoroughly cooled.

IMPORTANT NOTE: IF YOU MUST REMOVE THE ASH PAN WHILE THE STOVE IS OPERATING, IT IS ESSENTIAL THAT THE STOVE'S GLASS DOOR IS OPENED SLIGHTLY BEFORE OPENING THE ASH PAN DOOR. Failure to do so may cause damage to the appliance, especially the glass, because an excess of air intake could cause the stove to overfire.

Leaving the ash door of the stove open allows an uncontrolled air supply into the stove and may allow the stove to burn at a rate beyond its design capability. When removing ash pan, open the stove's glass door slightly and replace the ash pan as soon as possible. Do not leave the ash pan door open during normal operation.

Guidelines for Safe Operation

Due to high temperatures, the appliance should be located out of traffic and away from furniture and draperies. Advise all adults and especially children to be alert to the hazard of high temperatures and that they should stay away to avoid burns.

Supervise young children when they are in the same room as the appliance and/or use a fire guard.

It is imperative that the control compartments and circulating air passageways of the appliance be kept clean.

The appliance should be inspected before use and the chimney cleaned at least annually. More frequent cleaning may be required due to poor operation, installation, or low quality fuel.

CAUTION:

HOT WHILE IN OPERATION. DO NOT TOUCH. KEEP CHILDREN, CLOTHING AND FURNITURE AWAY. CONTACT MAY CAUSE SKIN BURNS.

THIS ROOM HEATER IS AN APPLIANCE PRODUCING HEAT AND MAY CAUSE SEVERE BURNS IF TOUCHED. KEEP CHILDREN AWAY.

ALL FURNISHINGS AND OTHER MATERIALS SHOULD BE KEPT A CONSIDERABLE DISTANCE FROM THE APPLIANCE.

DO NOT OVER-FIRE. IF ANY PORTION OF UNIT OR CHIMNEY CONNECTOR STARTS TO GLOW, YOU ARE OVER-FIRING.

This unit is designed as a radiant room heater and should be used for no other purpose. Be sure to provide combustion air into the dwelling when using the appliance. A partially open window or outside air register in the vicinity of the unit would be acceptable for this purpose.

Flue gas temperature

The most important aspect of stove operation is maintaining a high combustion temperature. If the combustion of the fuel is at the correct temperature, most of the soot and tars (hydrocarbons) are burned. These hydrocarbons, when not burned, can be seen as tar and creosote deposits on the internal surfaces of the stove, glass and chimney surfaces. To assist in maintaining these temperatures, a surface-mounted stove thermometer is recommended.

High combustion temperatures are the secret to clean glass operation. When loading wood, add one or two logs at a time, depending on size. Loading the appliance full of damp wood on a low fire is certain to cause poor combustion efficiency, resulting in tar and dirty glass.

It is recommended that you heat your stove to at least 400°F before reducing the air controls. This procedure should always be carried out after reloading.

Unattended Fires

Many structure fires have resulted when a slow burning fire has been left unattended for an extended period of time. These fires normally occur because combustible materials close to an appliance become heated to the ignition point by an over-fired appliance which the operator thought was safely “throttled down.”

Fire intensity is a function of several factors. One of these factors is draft. Normally, increasing draft increases fire intensity. Conversely, increasing the fire intensity will increase draft. Draft can also be affected by external factors such as wind strength and direction, outside temperature, airflow in or out of the structure, and so forth. If one of these factors changes, the draft of a low-burning appliance may increase. This increased draft may cause dangerously high temperatures to develop, possibly causing failure of the unit or flue, or ignition of nearby combustibles. Closing down the combustion air flow controls may not guarantee that this will not happen. Exercise extreme caution if a fire must be left unattended.

Procedure to Follow in Case of a Chimney Fire

- A. Prepare to evacuate to ensure everyone’s safety. Have a well-understood plan of action for evacuation. Have a place outside where everyone is to meet.
- B. Close all the air controls on the stove.
- C. Call the fire department. Have a fire extinguisher handy.
- D. After the chimney fire is out, the chimney must be cleaned and checked for stress and cracks before re-use. Also check combustibles around the chimney and the roof.

Check daily for creosote build-up until experience shows how often you need to clean to be safe. Be aware that the hotter the fire, the less creosote is deposited. Weekly cleaning may be necessary in mild weather even though monthly cleaning may be enough in the coldest months. Contact your local municipal or provincial fire authority for more information on how to handle a chimney fire. It is extremely important to have a clear plan on how to handle a chimney fire.

Choice of Firewood

Some types of wood are easier to light than others. The best fire wood, and easiest to light, is always dry wood. Using dry wood will minimize creosote buildup. Damp wood has far less heating power. It is difficult to light, burns badly and gives off smoke. This lowers the combustion temperature of the fire, and therefore the output. Above all, the use of damp wood causes the formation of deposits (tarring and soot staining) on the window glass and in the chimney flue, and could eventually cause a chimney fire.

Logs up to 18 inches in length allow for better stacking, filling and operation of your stove. Use dry wood which, by definition, is wood which has been dried under cover for more than 18 months so that the logs contain less than 20% moisture.

Wood supplied in ready-cut lengths stored immediately under a ventilated shelter dries quicker than wood stocked in high piles. Quarters (split wood) dry quicker than round logs. Wood which is too small to split must be drained, by removing some of the bark. Round logs left in the open for more than a year end up rotten. The drying time for the fire wood should be at least 18 months to 2 years. This period can be shortened (12 to 15 months) if the wood is cut to the right length and immediately stored under a ventilated shelter.

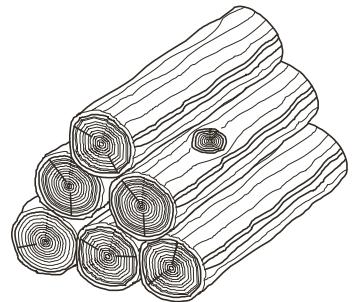

DO NOT USE FUELS OTHER THAN SEASONED WOOD.

NEVER USE GASOLINE, GASOLINE-TYPE LANTERN FUEL, KEROSENE, CHARCOAL LIGHTER FLUID, OR SIMILAR LIQUIDS TO START OR “FRESHEN UP” A FIRE IN THIS HEATER. KEEP ALL SUCH LIQUIDS WELL AWAY FROM THE HEATER WHILE IN USE.

DO NOT BURN TRASH OR FLAMMABLE FLUIDS SUCH AS GASOLINE, NAPHTHA OR ENGINE OIL.

Heating the air in a closed building decreases the relative humidity of the air, which will dry wood and other combustible materials. This drying lowers the ignition temperature of these materials, thus increasing the fire hazard. To reduce the risk of fire, some provision should be made for replenishing moisture to the air whenever a structure is being heated for extended periods.

Maintenance

WARNING: DO NOT CLEAN STOVE WHILE HOT.

Always keep the area around the unit clean and clear of furniture and other objects. Keep all furniture and drapery a minimum of 36" (914 mm) from the heater. Inspect the entire unit frequently for proper operation, fit and soundness of parts. If any malfunctioning, cracked, broken, or loose parts or other problems are noted, contact your dealer or qualified serviceman to inspect and repair the unit.

DO NOT OPERATE THE UNIT IF INSTALLED OR FUNCTIONING IMPROPERLY.

Check the fit and seal of the doors and ash pan door frequently. For proper operation, an airtight seal must be maintained around these openings. If the seal is not tight, inspect the gasket. If the gasket needs replacement, contact your dealer. If the gasket is in good condition, check the closure latch screws; if these are loose, tighten with a screwdriver and retest the seal (see Door Handle Adjustment, p. 19).

Integrated Airwash System

Your stove is equipped with an integrated airwash system which uses hot air to keep the window glass free of staining. Properly operated, your glass will remain clean, and any slight sooting which may occur when the stove is lit will usually clear when the stove heats to its normal operating temperature. If staining occurs, probably the best method for cleaning is to operate the stove with dry seasoned wood. Increase the operating rate until the fire is well established. Then turn the burn rate down to between position 1 and 2. The combustion temperature will now slowly clear the staining from the glass door.

Manual Cleaning of the Glass

Before attempting to clean your stove's glass the stove must be extinguished and allowed to cool. The glass in your stove is specially formulated to withstand the very high temperatures and proprietary glass cleaners are not recommended as their compositions may contain chemicals that will weaken or etch into the glass.

Newspaper moistened with water to which a little vinegar has been added will normally remove most staining, but for really stubborn marks, gentle polishing with fine steel wool lubricated with a few drops of dish washing detergent will need to be employed. Great care must be taken not to clean the glass too vigorously as particles of grit may have adhered with the stain and these could cause scratching if dragged across the glass. However well the stove burns it will eventually become necessary to clean the glass, but if cleaning becomes necessary too often, we advise you to review your operating procedures to determine whether cleaner and more efficient combustion can be achieved.

CAUTION: NEVER OPERATE YOUR STOVE WITH BROKEN GLASS

Cleaning the Stove Body

Cleaning of the stove body must only be done when the stove is cold. Stoves with an enamel finish should be cleaned with a damp cloth, or very gentle use of a cleaner recommended for enamel finishes. It should be noted that even approved cleaners will damage the highly polished finish of the stove if used too vigorously. All traces of the cleaner must be removed before the stove is lit and no finishing polishes must ever be used as these will leave unsightly streaks on the stove when it becomes hot.

Stoves with a painted finish must never be cleaned with a cloth as the texture of the paint will abrade and collect lint from the cloth which becomes difficult to remove. Vigorous brushing with a stiff bristle paint brush will remove all dust, but where the paint is marked, the stains are better obliterated with a spray of suitable stove paint rather than attempts made to clean them off.

In case of condensation, clean the affected areas before they dry.

WARNING

If your stove suddenly emits smoke, open a window, turn down the firing rate of the stove and leave to burn out. A chimney blocked, whether because of accumulated soot or even by a dead bird will cause any fire to fill the house with carbon monoxide.

Creosote Formation and Need for Removal

When wood is burned slowly, it produces tar and other organic vapors, which combine with expelled moisture to form creosote. The creosote vapors condense in the relatively cool chimney flue of a slow burning fire. As a result, creosote residue accumulates on the flue lining. When ignited, this creosote makes an extremely hot fire.

The chimney connector and chimney should be inspected at least once every two months during the heating season to determine if a creosote build-up has occurred.

The stove has a baffle at the top of the combustion chamber which simply lifts upwards and can be removed. With the baffle removed, all ash deposits in the stove's flue outlet can be removed.

The chimney connector must be in good condition and kept clean. If creosote has accumulated (1/8 "(3 mm) or more) it should be removed to reduce the risk of a chimney fire. Experienced chimney servicing personnel should be consulted.

Summer Shut Down

At the end of each heating season the entire installation should be thoroughly cleaned and examined for soundness. This should include having the chimney examined by a qualified technician. It should be left with one of its air supplies open to encourage the evaporation of any rain that may enter the chimney. For extra protection, absorbent crystals may be placed, or the stove interior may be coated with a moisture repellent such as WD40. All operating mechanisms should be lubricated with oil; this applies particularly to the door handle shafts and latching blades.

Door Handle Adjustment

Your stove is equipped with an adjustable door latch. For correct operation, the stove door must be airtight when closed. To adjust the door handle latch, loosen the locking nut and adjust the bolt in or out as required. Retighten the locking nut. The adjustment should be made in such a way that when the handle is in its closed position the door is airtight.

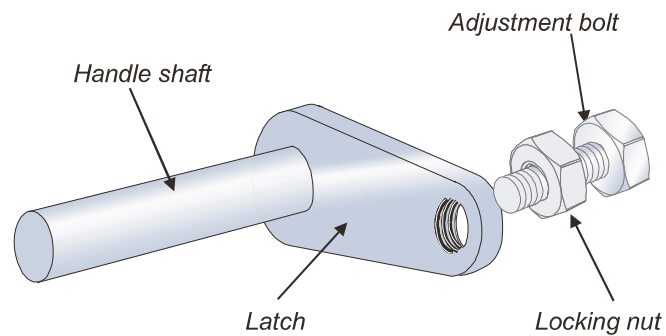

Ash Pan Door Adjustment

To ensure an air tight seal on the ash pan door, the stove is equipped with an ash pan door lever adjustment.



Adjust the screw at the end of the ash pan door lever to give a positive action when closing. Do not over adjust. The closing action of the lever should have a gentle resistance.

Spare Parts

Parts Diagram - Model S33

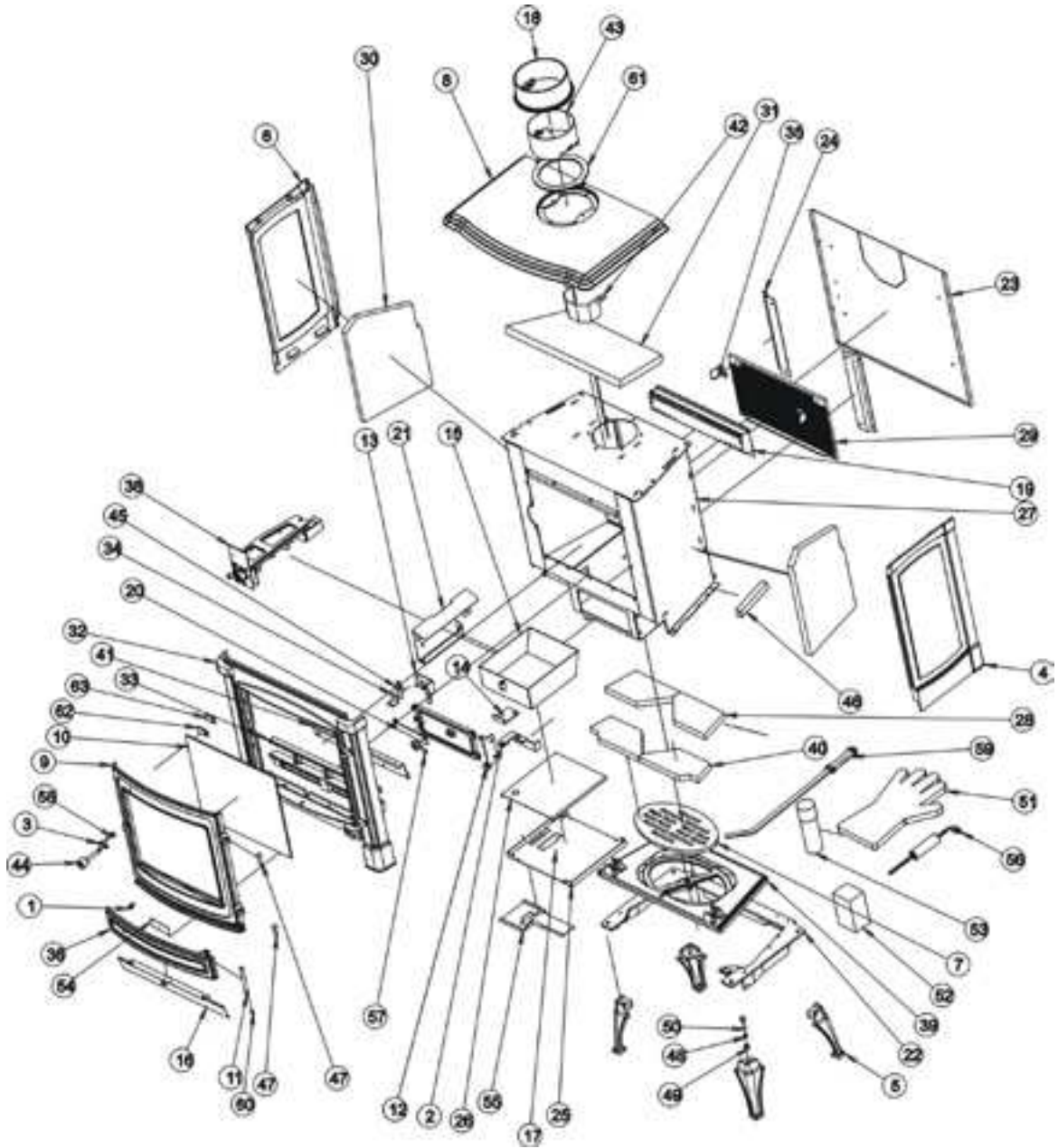

Parts List – Model S33

EXPLODED VIEW #	ORDER NUMBER	PART NAME	QUANTITY	FACTORY CODE
1	38551	EXCENTRIC RETAINER	1	4/00000174490000
3	32812	FRONT DOOR LATCH	1	3/19792566720000
4	37717	RIGHT SIDE PANEL PAINTED GRAPHITE	1	2/19992305703055
4	37719	RIGHT SIDE PANEL BLACK ENAMEL	1	2/19992305700140
5	37720	LEG PAINTED GRAPHITE	4	2/19992001703055
5	37722	LEG BLACK ENAMEL	4	2/19992001700140
6	37714	LEFT SIDE PANEL PAINTED GRAPHITE	1	2/19992300703055
6	37716	LEFT SIDE PANEL BLACK ENAMEL	1	2/19992300700140
7	38260	GRATE	1	2/39944118703055
8	42298	TOP PLATE PAINTED GRAPHITE	1	2/30292030703055
8	42300	TOP PLATE BLACK ENAMEL	1	2/30292030700140
9	41969	FRONT DOOR PAINTED GRAPHITE	1	2/19992040853055
9	41969	FRONT DOOR BLACK ENAMEL	1	2/19992040850140
10	41769	GLASS	1	4/00000023810000
11	43807	CHARNIERE PORTE INFERIEUR	1	3/H33##478103055
12	42725	ASHPAN DOOR HINGE	1	3/30292475703055
13	42855	ASHPAN HANDLE AXIS SUPPORT BRACKET	1	3/30292474703055
14	42903	HINGE RETAINER	1	3/30046780700000
15	42731	ASHPAN	1	3/30292580703055
16	42854	LOWER DOOR PLATE	1	3/30292915703055
18	43067	FLUE COLLAR PAINTED GRAPHITE	1	2/30292075703055
18	43066	FLUE COLLAR ENAMEL BLACK	1	2/30292075700140
19	43639	SECONDARY AIR DISTRIBUTOR	1	3/30292856700000
20	42902	ASHPAN HANDLE	1	4/00000150790000
21	43171	ASH DEFLECTOR	1	3/30292585753055
22	43169	CAST IRON BASE	1	2/30292005703055
23	43170	BACK PANEL	1	3/30292409703055
24	43175	PROTECTOR SUPPORT BRACKET	2	3/30292650703055
25	43329	FLOOR PROTECTOR	1	3/30292515703055
26	43335	LOWER PLATE	1	3/30292938703055
27	43558	FIREBOX	1	3/30292412803055
28	43432	REAR HORIZONTAL FIREBRICK PANEL	2	4/00000039540000
29	43556	REAR PROTECTOR	1	2/30292170803055
30	43431	SIDE FIREBRICK PANEL	2	4/00000039530000
31	43428	BAFFLE	1	4/00000039520000
32	43551	FRONT PANEL PAINTED GRAPHITE	1	2/30292025803055
32	42297	FRONT PANEL ENAMEL BLACK	1	2/30292025800140
33	43558	FRONT PROTECTOR	1	2/30292173803055
34	43443	RETAINER	1	3/30292846803055
35	43637	FIXING BRACKET	2	3/30292780710000
36	43497	ASHPAN DECORATIVE DOOR PAINTED GRAPHITE	1	2/30292313703055
36	43494	ASHPAN DECORATIVE DOOR ENAMEL BLACK	1	2/30292313700140
37	43637	ASHPAN DOOR PAINTED BLACK	1	2/30292055703001
38	43692	AIR INTAKE CONTROL MECHANISM SET	1	4/00000236080000
39	43685	GRATE SUPPORT	1	2/30244110803055
40	43683	FRONT HORIZONTAL FIREBRICK PANEL	2	4/00000039610000
41	43520	FRONT DECORATIVE PLATE	1	3/30292594803055
42	43681	FLUE BAFFLE	1	3/30292563800000
43	43677	FLUE COLLAR PROTECTOR	1	3/30292543700000
44	44071	FRONT DOOR HANDLE SET	1	3/S33##870704555
45	43890	PERMANENT MINIMUM AIR INTAKE	1	3/30292577800000
46	44015	U BASE	6	3/30292572700000
47	39938	FRONT DOOR HINGE PINS	2	4/00000071000000
48	4838	WASHER D8	4	4/00000050020000
49	13095	HEXAGON NUT M8	4	4/00000240350000
50	13791	HEXAGON HEAD SCREW M8	4	4/00000240320000
51	38552	LEATHER GLOVE	1	4/00000252020000
52	42115	REMOTE CONTROL TRANSMITTER KIT	1	4/00000193530000
53	40788	SPRAY PAINT GRAPHITE	1	4/00007090490000
54	44286	LOGO PLATE	1	4/00000225050000
55	43962	RECEIVER SUPPORT BRACKET	1	3/S33##622703055
57	42744	LATCH	1	3/30292566703055
58	27109	STAINLESS STEEL SCREW M6	1	4/00000240650000
59	20021	POKER	1	4/00000038080000
60	32726	AXIS CLIP	1	4/00000060180000
61	11841	GASKET	1	4/00000010570000
62	31860	GLASS CLIP GASKET	4	4/00000012260000
63	28104	PYREX CLIP	4	3/39492780100000
		GASKET ROPES		
	40433	PYREX GASKET ROPE D8	1350 mm	4/00000012660000
	16116	ASHPAN DOOR GASKET ROPE	630 mm	4/00000011110000
	18826	FRONT DOOR GASKET ROPE	1590 mm	4/00000011430000

Parts Diagram - Model H33

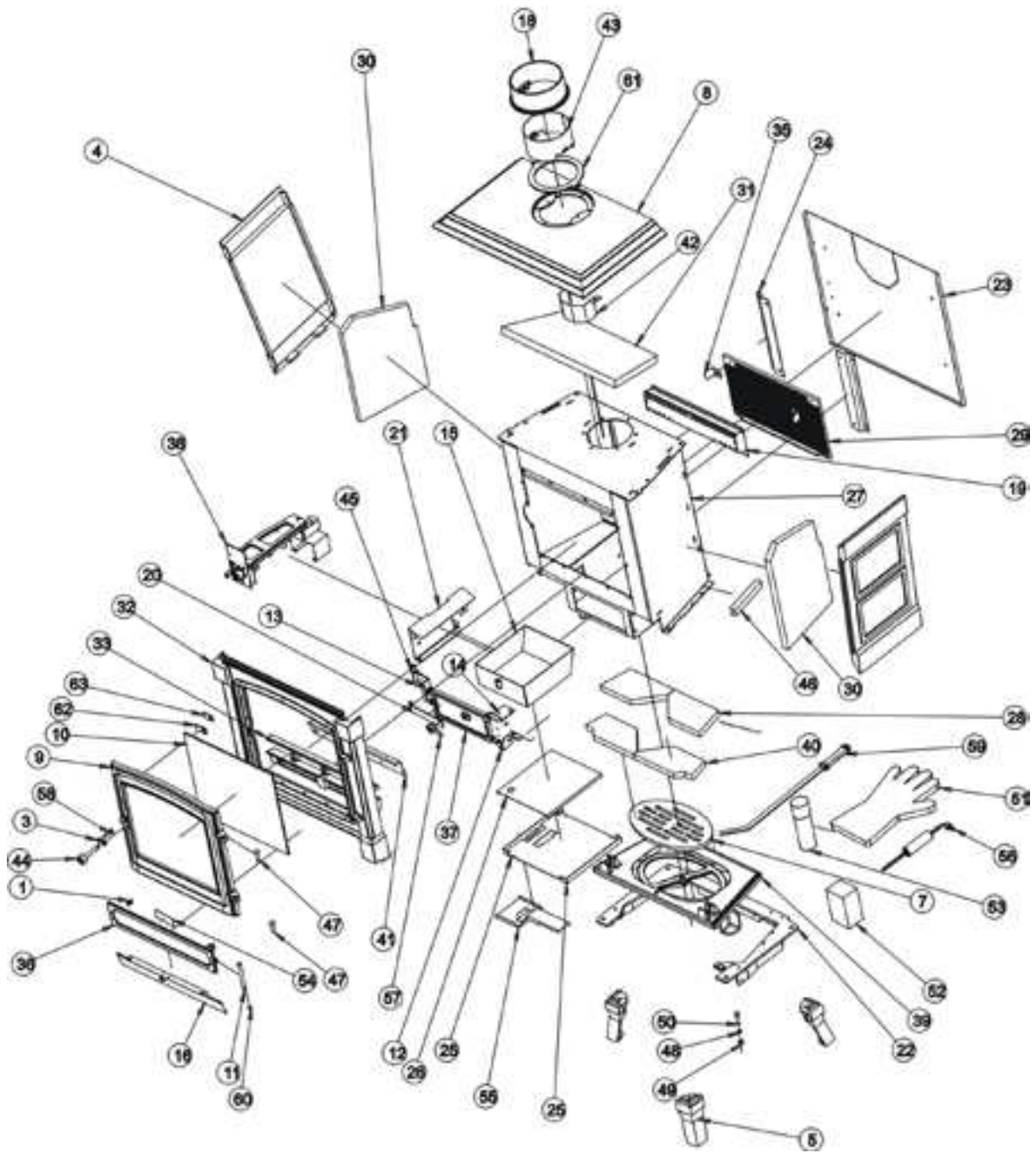

Parts List - Model H33

EXPLODED VIEW #	ORDER NUMBER	PART NAME	QUANTITY	FACTORY CODE
1	38547	EXCENTRIC RETAINER	1	4/00000174490000
3	32812	FRONT DOOR LATCH	1	3/19792566720000
4	37711	SIDE PANEL PAINTED GRAPHITE	2	2/19992301203055
4	37713	SIDE PANEL ENAMEL BLACK	2	2/19992301200140
4	39326	SIDE PANEL ENAMEL GREEN	2	2/19992301203055
5	35273	LEG PAINTED GRAPHITE	4	2/19992001703055
5	39299	LEG ENAMEL BLACK	4	2/19992301200140
5	39298	LEG ENAMEL GREEN	4	2/19992301203055
7	38256	FUEL GRATE	1	2/39944118703055
8	43798	TOP PLATE PAINTED GRAPHITE	1	2/H33##030100140
8	43800	TOP PLATE ENAMEL BLACK	1	2/H33##030103055
8	43801	TOP PLATE ENAMEL GREEN	1	2/H33##030103055
9	44376	FRONT DOOR PAINTED GRAPHITE	1	2/H33##040803055
9	44378	FRONT DOOR ENAMEL BLACK	1	2/H33##040800140
9	44379	FRONT DOOR ENAMEL GREEN	1	2/H33##040803055
10	43820	WINDOW GLASS	1	4/00000025090000
11	43806	LOWER DOOR HINGE	1	3/H33##478103055
12	42721	ASHPAN DOOR HINGE	1	3/30292475703055
13	42851	ASHPAN HANDLE AXIS SUPPORT BRACKET	1	3/30292474703055
14	44795	HINGE RETAINER	1	.3/30046780700000
15	42728	ASHPAN	1	3/30292580703055
16	43806	LOWER DOOR PLATE	1	3/H33##915103055
18	43067	FLUE COLLAR PAINTED BLACK	1	2/30292075703055
18	43066	FLUE COLLAR ENAMEL BLACK	1	2/30292075700140
18	43064	FLUE COLLAR ENAMEL GREEN	1	2/30292075703055
19	43637	SECONDARY AIR DISTRIBUTOR	1	3/30292856700000
20	42898	ASHPAN HANDLE	1	4/00000150790000
21	43168	ASH DEFLECTOR	1	3/30292585753055
22	43166	CAST IRON BASE	1	2/30292005703055
23	43167	BACK PANEL	1	3/30292409703055
24	43169	PROTECTOR SUPPORT BRACKET	2	3/30292650703055
25	43326	FLOOR PROTECTOR	1	3/30292515703055
26	43331	LOWER PLATE	1	3/30292938703055
27	43557	FIREBOX	1	3/30292412803055
28	43428	BACK HORIZONTAL FIREBRICK PANEL	2	4/00000039540000
29	43554	BACK PROTECTOR	1	2/30292170803055
30	43427	SIDE FIREBRICK PANEL	2	4/00000039530000
31	43426	BAFFLE	1	4/00000039520000
32	44370	FRONT PANEL PAINTED GRAPHITE	1	2/H33##025803055
32	44372	FRONT PANEL ENAMEL BLACK	1	2/H33##025800140
32	44375	FRONT PANEL ENAMEL GREEN	1	2/H33##025803055
33	43556	FRONT PROTECTOR	1	2/30292173803055
35	44795	FIXING BRACKET	2	3/30292780710000
36	43802	ASHPAN DECORATIVE DOOR PAINTED GRAPHITE	1	2/H33##313103055
36	43804	ASHPAN DECORATIVE DOOR ENAMEL BLACK	1	2/H33##313100140
36	43805	ASHPAN DECORATIVE DOOR ENAMEL GREEN	1	2/H33##313103055
37	43634	ASHPAN DOOR PAINTED BLACK	1	2/30292055703001
38	43690	AIR INTAKE CONTROL MECHANISM SET	1	4/00000236080000
39	43683	GRATE SUPPORT	1	2/30244110803055
40	43679	FRONT HORIZONTAL FIREBRICK PANEL	2	4/00000039610000
41	43808	FRONT DECORATIVE PLATE	1	3/H33##594103055
42	43680	FLUE BAFFLE	1	3/30292563800000
43	43676	FLUE CONNECTOR PROTECTOR	1	3/30292543700000
44	43689	FRONT DOOR HANDLE SET	1	3/S33##870704555
45	43889	PERMANENT MINIMUM AIR INTAKE	1	3/30292577800000
46	44009	U FRAME	6	3/30292572700000
47	31848	FRONT DOOR HINGE PINS	2	4/00000071000000
48	4826	WASHER D8	4	4/00000050020000
49	13083	HEXAGON NUT M8	4	4/000000240350000
50	13783	HEXAGON HEAD SCREW M8	4	4/000000240320000
51	38548	LEATHER GLOVE	1	4/000000252020000
52	TLCS1	REMOTE CONTROL TRANSMITTER KIT	1	4/00000193530000
53	40785	SPRAY PAINT GRAPHITE	1	4/00007090490000
54	44497	LOGO PLATE	1	4/000000225320000
55	43962	RECEIVER SUPPORT BRACKET	1	3/S33##622703055
57	42740	LATCH	1	3/30292566703055
58	27106	STAINLESS STEEL SCREW M6	1	4/000000240650000
59	20017	POKER	1	4/00000038080000
60	32723	AXIS CLIP	1	4/00000060180000
61	11838	GASKET	1	4/00000010570000
62	31856	PYREX CLIP GASKET	4	4/00000012260000
63	28100	PYREX CLIP	4	3/39492780100000
		GASKET ROPES		
	40163	PYREX GLASS GASKET ROPE D8	1350 mm	4/00000012660000
	15927	ASHPAN DOOR GASKET ROPE	630 mm	4/00000011110000
	18355	FRONT DOOR GASKET ROPE	1590 mm	4/00000011430000

Parts Diagram - Model X33

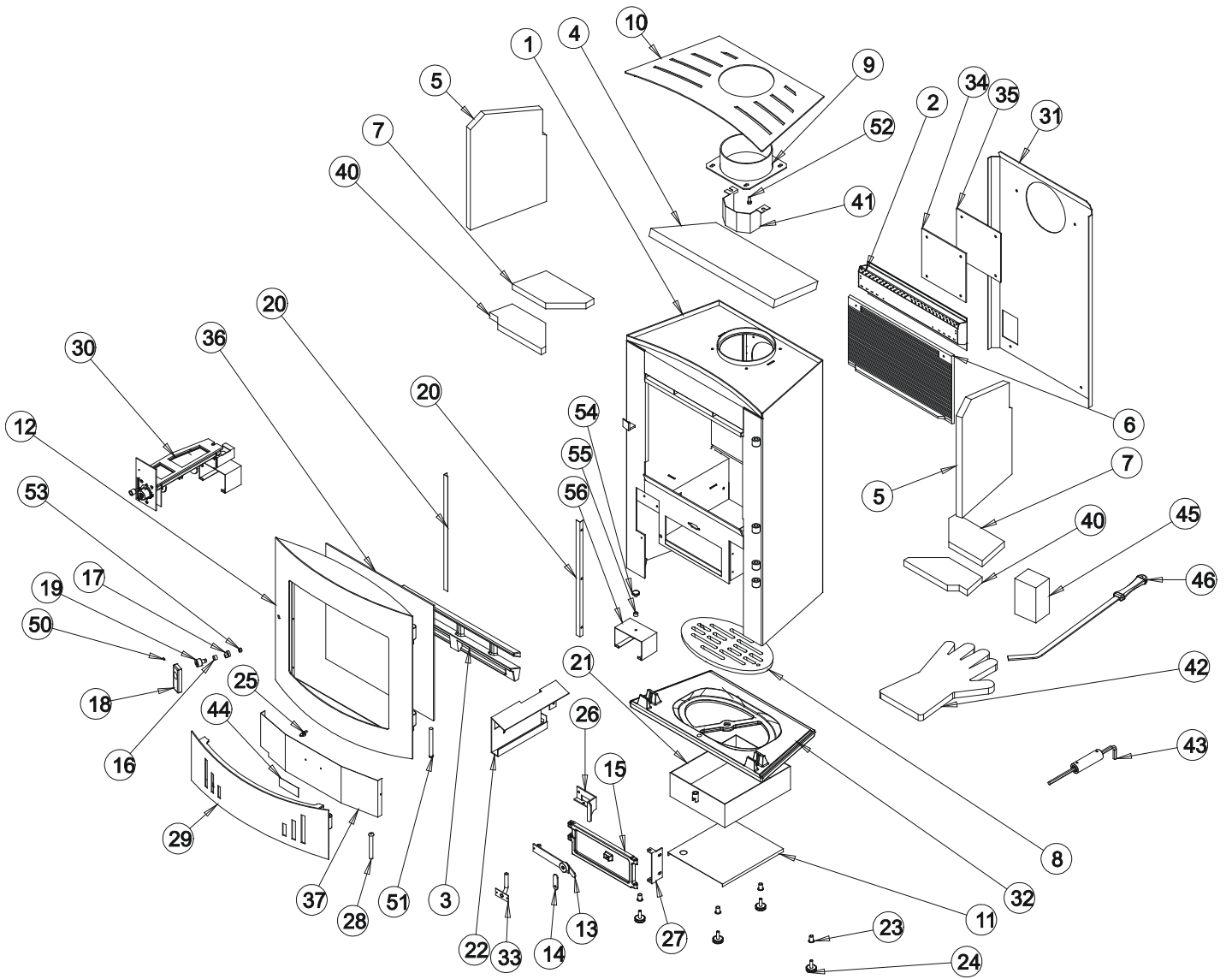

Parts List - Model X33

EXPLODED VIEW #	ORDER NUMBER	PART NAME	QUANTITY	FACTORY CODE
1	46211	FIREBOX	1	3/X33##412903055
2	43637	SECONDARY AIR BOX	1	/3029285670000
3	43556	LOG GUARD	1	2/30292173803055
4	43426	BAFFLE	1	4/00000039520000
5	43427	FIREBRICK SIDE PANEL	2	4/00000039530000
6	43554	BACK PROTECTOR	1	2/30292170803055
7	43428	BACK HORIZONTAL FIREBRICK	2	4/00000039540000
8	38256	GRATE	1	2/39944118703055
9	43067	FLUE CONNECTOR	1	3/XH33##485704555
10	45747	TOP PLATE	1	3/X33##450704555
11	43331	PROTECTOR	1	3/30292938703055
12	45232	FRONT DOOR	1	3/X33##455704537
13	44572	ASHPAN HANDLE	1	3/30046871703055
14	44795	ASHPAN HANDLE RETAINER	1	3/19792566720000
15	45233	ASHPAN DOOR	1	2/30292055703055
16	39200	SPACER	1	4/00000172540000
17	45483	LATCH	1	3/30292566703055
18	43822	DOOR HANDLE DECORATIVE BRACKET	1	3/XH33##600704537
19	44040	DOOR HANDLE	1	3/X33##870704537
20	28100	PYREX GLASS RETAINERS	2	3/X33##481863055
21	42728	ASHPAN	1	3/X33##580703055
22	43168	ASH DEFLECTOR	1	3/XH33##585803055
23	14745	NUT RIVETS	4	4/00000070190000
24	26416	LEG RESTS	4	4/00000140340000
25	45483	LOWER DOOR LATCH	1	4/00000174490000
26	42855	ASHPAN HANDLE SUPPORT	1	3/30292474703055
27	44904	ASHPAN DOOR HINGE	1	3/30292475703055
28	43668	LOWER DOOR AXIS	1	4/00000071220000
29	45233	LOWER DOOR	1	3/X33##430954537
30	43690	AIR INTAKE MECHANISM	1	4/00000236080000
31	44019	BACK PANEL	1	3/X33##409703055
32	43683	GRATE SUPPORT	1	2/30244110803055
33	43889	MINIMUM PRIMARY AIR INTAKE	1	3/X33##810900000
34	43890	GASKET	1	4/00000015500000
35	43891	CLOSING PLATE	1	3/XH33##753703055
36	44928	GLASS	1	4/00000025100000
37	45105	DECORATIVE PANEL	1	3/XH33##663703055
40	43679	FRONT HORIZONTAL FIREBRICK	2	4/00000039610000
41	43680	FLUE BAFFLE	1	3/30292563800000
42	38548	LEATHER GLOVE	1	4/00000252020000
43	44896	DOOR HANDLE TOOL	1	4/00000150940000
44	44799	LOGO PLATE	1	4/00000225280000
45	TLCX1	REMOTE CONTROL SET	1	4/00000193530000
46	20017	POKER	1	4/00000038080000
50	43452	ALLEN SCREW M4X6	2	4/00000244730000
51	18373	DOOR AXIS	2	4/00000171990000
52	15491	STAINLESS STEEL SCREW M6X16	4	4/00000240860000
53	41581	NUT M6	1	4/00000242260000
56	43429	RECEIVER SUPPORT	1	3/30292622703055
54	43442	MAGNET D25	1	4/00000039550000
55	31037	SPACER D10/8 8mm	1	4/00000173890000

Parts Diagram - Model R33

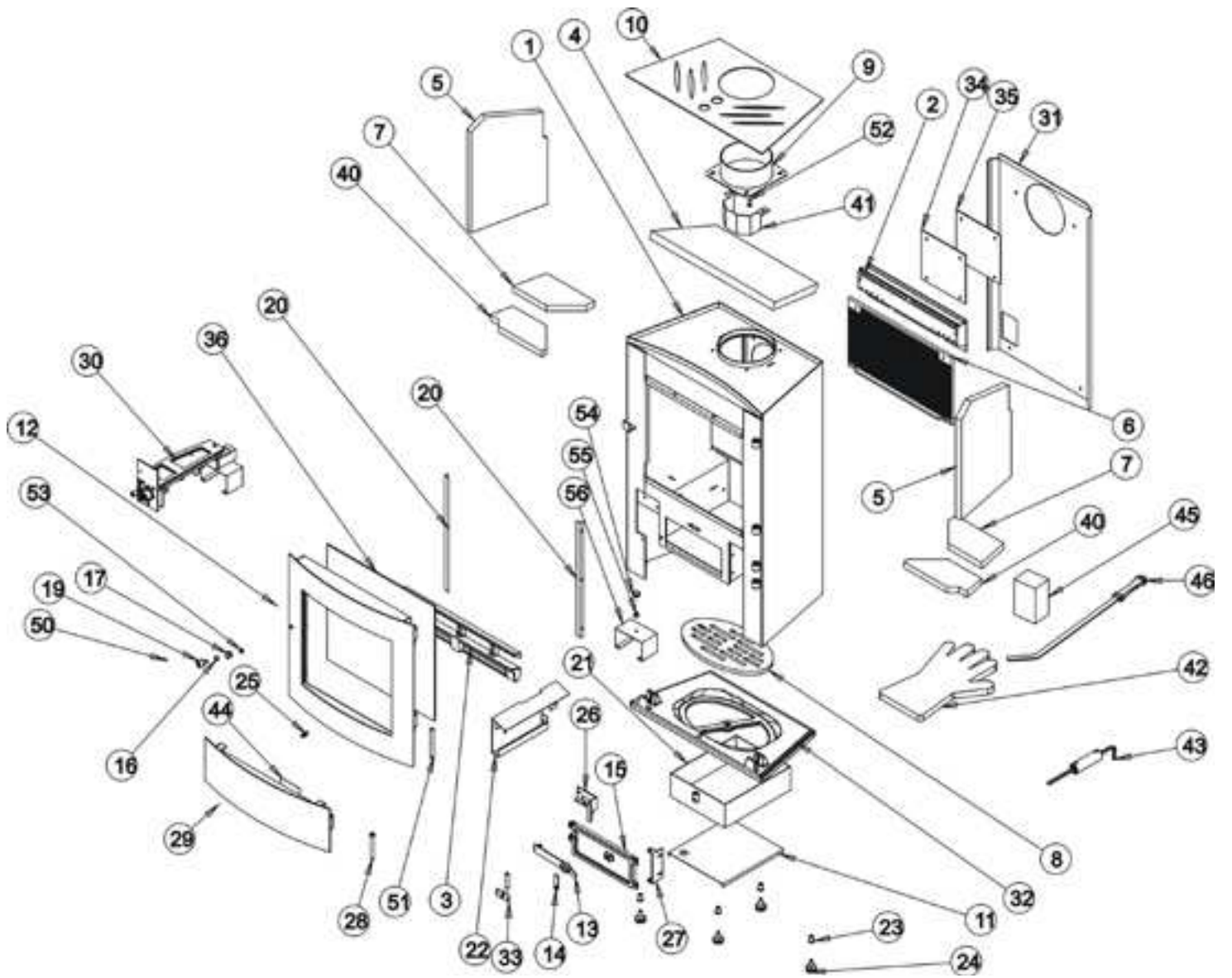

Parts List - Model R33

EXPLODED VIEW #	ORDER NUMBER	PART NAME	QUANTITY	FACTORY CODE
1	46211	FIREBOX	1	3/X33###412903055
2	43637	SECONDARY AIR BOX	1	/3029285670000
3	43556	LOG GUARD	1	2/30292173803055
4	43426	BAFFLE	1	4/00000039520000
5	43427	FIREBRICK SIDE PANEL	2	4/00000039530000
6	43554	BACK PROTECTOR	1	2/30292170803055
7	43428	BACK HORIZONTAL FIREBRICK	2	4/00000039540000
8	38256	GRATE	1	2/39944118703055
9	43067	FLUE CONNECTOR	1	3/XH33##485704555
10	45747	TOP PLATE	1	3/X33###450704555
11	43331	PROTECTOR	1	3/30292938703055
12	45000	FRONT DOOR	1	3/X33###455704537
13	44572	ASHPAN HANDLE	1	3/30046871703055
14	44795	ASHPAN HANDLE RETAINER	1	3/19792566720000
15	45233	ASHPAN DOOR	1	2/30292055703055
16	39200	SPACER	1	4/00000172540000
17	45483	LATCH	1	3/30292566703055
18	43822	DOOR HANDLE DECORATIVE BRACKET	1	3/XH33##600704537
19	44040	DOOR HANDLE	1	3/X33###870704537
20	28100	PYREX GLASS RETAINERS	2	3/X33###481863055
21	42728	ASHPAN	1	3/X33###580703055
22	43168	ASH DEFLECTOR	1	3/XH33#585803055
23	14745	NUT RIVETS	4	4/00000070190000
24	26416	LEG RESTS	4	4/00000140340000
25	45483	LOWER DOOR LATCH	1	4/00000174490000
26	42855	ASHPAN HANDLE SUPPORT	1	3/30292474703055
27	44904	ASHPAN DOOR HINGE	1	3/30292475703055
28	43668	LOWER DOOR AXIS	1	4/00000071220000
29	44998	LOWER DOOR	1	3/X33###430954537
30	43690	AIR INTAKE MECHANISM	1	4/00000236080000
31	44019	BACK PANEL	1	3/X33###409703055
32	43683	GRATE SUPPORT	1	2/30244110803055
33	43889	MINIMUM PRIMARY AIR INTAKE	1	3/X33###810900000
34	43890	GASKET	1	4/00000015500000
35	43891	CLOSING PLATE	1	3/XH33##753703055
36	44928	GLASS	1	4/00000025100000
37	45105	DECORATIVE PANEL	1	3/XH33##663703055
40	43679	FRONT HORIZONTAL FIREBRICK	2	4/00000039610000
41	43680	FLUE BAFFLE	1	3/30292563800000
42	38548	LEATHER GLOVE	1	4/00000252020000
43	44896	DOOR HANDLE TOOL	1	4/00000150940000
44	44799	LOGO PLATE	1	4/00000225280000
45	TLCX1	REMOTE CONTROL SET	1	4/00000193530000
46	20017	POKER	1	4/00000038080000
50	43452	ALLEN SCREW M4X6	2	4/00000244730000
51	18373	DOOR AXIS	2	4/00000171990000
52	15491	STAINLESS STEEL SCREW M6X16	4	4/00000240860000
53	41581	NUT M6	1	4/00000242260000
56	43429	RECEIVER SUPPORT	1	3/30292622703055
54	43442	MAGNET D25	1	4/00000039550000
55	31037	SPACER D10/8 8mm	1	4/00000173890000

Safety Label - Models S33 and H33



UL Listed
UL 1482 ULC-9627
UL Classified
UL 1482 ULC-9627

DO NOT REMOVE THIS LABEL / NE PAS ENLEVER CETTE ETIQUETTE

CONTACT LOCAL BUILDING OR FIRE OFFICIALS ABOUT INSTALLATION AND RESTRICTIONS IN YOUR AREA. / RENSEIGNEZ-VOUS AUPRES DES AUTORITES LOCALES DE LA CONSTRUCTION ET DE LA PREVENTION DES INCENDIES AU SUIV DES RESTRICTIONS ET INSPECTIONS D'INSTALLATION DANS VOTRE REGION.

LISTED SOLID FUEL BURNING APPLIANCE SUITABLE FOR USE IN RESIDENTIAL INSTALLATIONS. / APPAREIL DE CHAUFFAGE A COMBUSTIBLES SOLIDES ADAPTE POUR INSTALLATIONS RESIDENTIELLES.



MODEL / MODELE:
 S33 H33

TESTED TO / TESTE AUX NORMES: UL 1482, ULC-9627
Room Heater, Solid Fuel Type / Appareil de Chauffage à Combustibles Solides

Serial Number / Numéro de Série Z-

PREVENT HOUSE FIRES - Install and use only in accordance with the manufacturer's installation and operating instructions. Contact your local building or fire officials about restrictions and installation inspection in your area. Refer to local building codes and manufacturer's instructions for precautions required for passing a chimney through a combustible wall or ceiling. Do not run a chimney connector through a combustible wall or ceiling. Do not connect this unit to a chimney flue serving another appliance. Clearances may be reduced by methods specified in NFPA 211, listed wall stands, pipe stands, or other means approved by local building or fire officials.

For use with solid wood fuel only (not wood).

Operate with hood door closed - open to feed fire only.

Do not use a grate to elevate fire - burn fire directly on hearth.

Do not operate with the ash door open.

DO NOT OVERFIRE - If heater or chimney connector glows, you are overfiring. Inspect and clean chimney frequently - under certain conditions of use, creosote buildup may occur rapidly.

PREVENTION DES INCENDIES: Installez et utilisez conformément aux instructions du fabricant. Renseignez-vous auprès des autorités locales de la construction et de la prévention des incendies au sujet des restrictions et inspections d'installation dans votre région. Des méthodes spéciales sont requises lors du passage d'un mur ou plafond. Vérifier les instructions du fabricant et les codes du bâtiment. Ne pas faire passer le tuyau de cheminée directement à travers une surface combustible. Ne pas connecter cet appareil à la cheminée d'un autre appareil. Les dégagements nécessaires des matériaux combustibles peuvent être réduits selon les méthodes spécifiées dans NFPA 211, avec des protections murales homologuées, des protections de cheminée homologuées, ou d'autres moyens approuvés par les autorités de la construction et de la prévention des incendies.

Pour usage uniquement avec du bois.

Faites fonctionner l'appareil avec les portes de chargement fermées - ouvrir uniquement pour charger.

Ne pas utiliser une grille supplémentaire pour élever le feu - faites le feu directement sur le foyer.

Ne pas faire fonctionner l'appareil avec la porte cendrier ouverte.

NE PAS SURCHAUFFER - Si une partie de l'appareil ou du raccordement de cheminée commencent à rougir, vous êtes en situation de surchauffe. Inspectez et nettoyez la cheminée fréquemment. Dans certaines conditions de fonctionnement (par exemple, usage au charbon) sans aération de combustion des ventouses) une formation de crasse peut se produire rapidement.

FREESTANDING INSTALLATION

STANDARD RESIDENTIAL FREESTANDING INSTALLATIONS REQUIRE: 4" clearance minimum to MSO block or 26 MSO listed steel connector with listed (type UL103-RT) factory-built chimney, suitable for use with solid fuels or masonry chimney / Pour les installations résidentielles: L'unité ou connecteur de cheminée de 4" de diamètre, en acier noir de minimum 26 MSO ou en acier inox de minimum 26 MSO avec une cheminée préfabriquée homologuée (type UL103-RT ou UL2 580) ou avec une cheminée maçonnée.

CLEARANCE REQUIREMENTS RÈGLEMENTS MINIMUMS DES MATÉRIELS COMBUSTIBLES	STANDARD RESIDENTIAL INSTALLATION (SINGLE WALL CONNECTOR) INSTALLATION RESIDENTIELLE STANDARD (TUYAU DE RACCORDEMENT À SIMPLE PAROI)	WITH DOOR (WALL CONNECTOR) TUYAU DE RACCORDEMENT À DOUBLE PAROI	ALCOVE INSTALLATION WITH DOUBLE WALL CONNECTOR INSTALLATION DANS UN ALCOVE (TUYAU DE RACCORDEMENT À DOUBLE PAROI)
A. SIDEWALL TO UNIT / DU MUR DE CÔTÉ AU POÊLE	4" (103mm)	4" (103mm)	12" (305mm)
B. BACKWALL TO UNIT / DU MUR ARRIÈRE AU POÊLE	12" (305mm)	12" (305mm)	12" (305mm)
C. CORNERWALL TO UNIT / DU MUR DU COIN AU POÊLE	12" (305mm)	7" (178mm)	NA
D. SIDEWALL TO CONNECTOR / DU MUR DE CÔTÉ AU RACCORD DE CHEMINÉE	14" (357mm)	14" (357mm)	21" (533mm)
E. BACKWALL TO CONNECTOR / DU MUR ARRIÈRE AU RACCORD DE CHEMINÉE	14" (357mm)	12" (305mm)	12" (305mm)
F. CORNERWALL TO CONNECTOR / DU MUR DU COIN AU RACCORD DE CHEMINÉE	12" (305mm)	14" (357mm)	NA
G. UNIT TO CEILING / DU POÊLE AU PLAFOND	18" (457mm)	18" (457mm)	18" (457mm)
H. FLOOR TO CEILING / DU SOL AU PLAFOND	22" (559mm)	22" (559mm)	22" (559mm)

**MINIMUM CLEARANCE TO COMBUSTIBLES
RÈGLEMENTS MINIMUMS AUX MATÉRIELS COMBUSTIBLES**

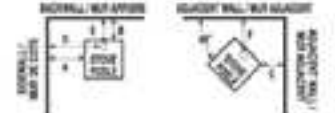

**NON-COMBUSTIBLE FLOOR PROTECTION
PROTECTION DE PLANCHER NON-COMBUSTIBLE**



ALCOVE INSTALLATION / INSTALLATION ALCOVE

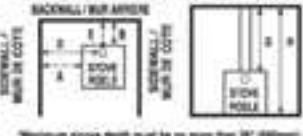

CAUTION: HOT WHILE IN OPERATION. DO NOT TOUCH. KEEP CHILDREN AND CLOTHING AWAY. CONTACT MAY CAUSE SKIN BURNS. SEE NAMEPLATE AND INSTRUCTIONS. KEEP FURNISHINGS AND OTHER COMBUSTIBLE MATERIALS A CONSIDERABLE DISTANCE AWAY FROM THE APPLIANCE. DO NOT OVERFIRE- IF HEATER OR CHIMNEY GLOWS, YOU ARE OVERFIRING.



ATTENTION: CHAUD LORS DU FONCTIONNEMENT. NE PAS TOUCHER. LE CONTACT PEUT CAUSER DES BRULURES A LA PEAU. GARDEZ LES ENFANTS, LES VETEMENTS, LES MEUBLES, ET TOUS LES MATERIAUX COMBUSTIBLES LOIN DE L'ESPACE DESIGNÉ DE L'APPAREIL. LIRE ATTENTIVEMENT LES ETIQUETTES ET LES INSTRUCTIONS. NE PAS SURCHAUFFER. SI L'APPAREIL OU LE TUYAU DE CHEMINÉE ROUGISSENT, VOUS SURCHAUFFEZ.

Manufactured By / Fabriqué par: Panbaries du Lion Development, Grootvill (Belgique)

U.S. ENVIRONMENTAL PROTECTION AGENCY
Certified to comply with July 1990 particulate emission standards:
Certifié conforme aux normes EPA de juillet 1990 pour les émissions de particules solides

Jul	Aug	Sep	Oct	Nov	Dec	Jan	Feb	Mar	Apr	May	Jun	Jul	Aug	Sep	Oct	Nov	Dec	
☐	☐	☐	☐	☐	☐	☐	☐	☐	☐	☐	☐	☐	☐	☐	☐	☐	☐	☐